

ABO valve

ELECTRIC ACTUATORS

Operating torque	up to 6000 Nm
Protection class	IP67 / Top flange - F03-F12
Power supply	110 / 220V AC 1PH 380 / 440V AC 3PH 50/60 Hz)*) *) upon request
Control power supply	230V AC, 50 Hz
Motor	Induction motor (Reversive motor)
Limit switches	Open/Close, SPDT, 250V AC 16A rating
Travel angels	90° +/- 10° (0° - 110°)
Ambient temperature	-20°C / +70°C (except option electronic board)



SERIES S97AQ

www.abovalve.com

ELECTRIC ACTUATOR DESING - SERIES S97AQ

Czech Industrial Valve Manufacturer

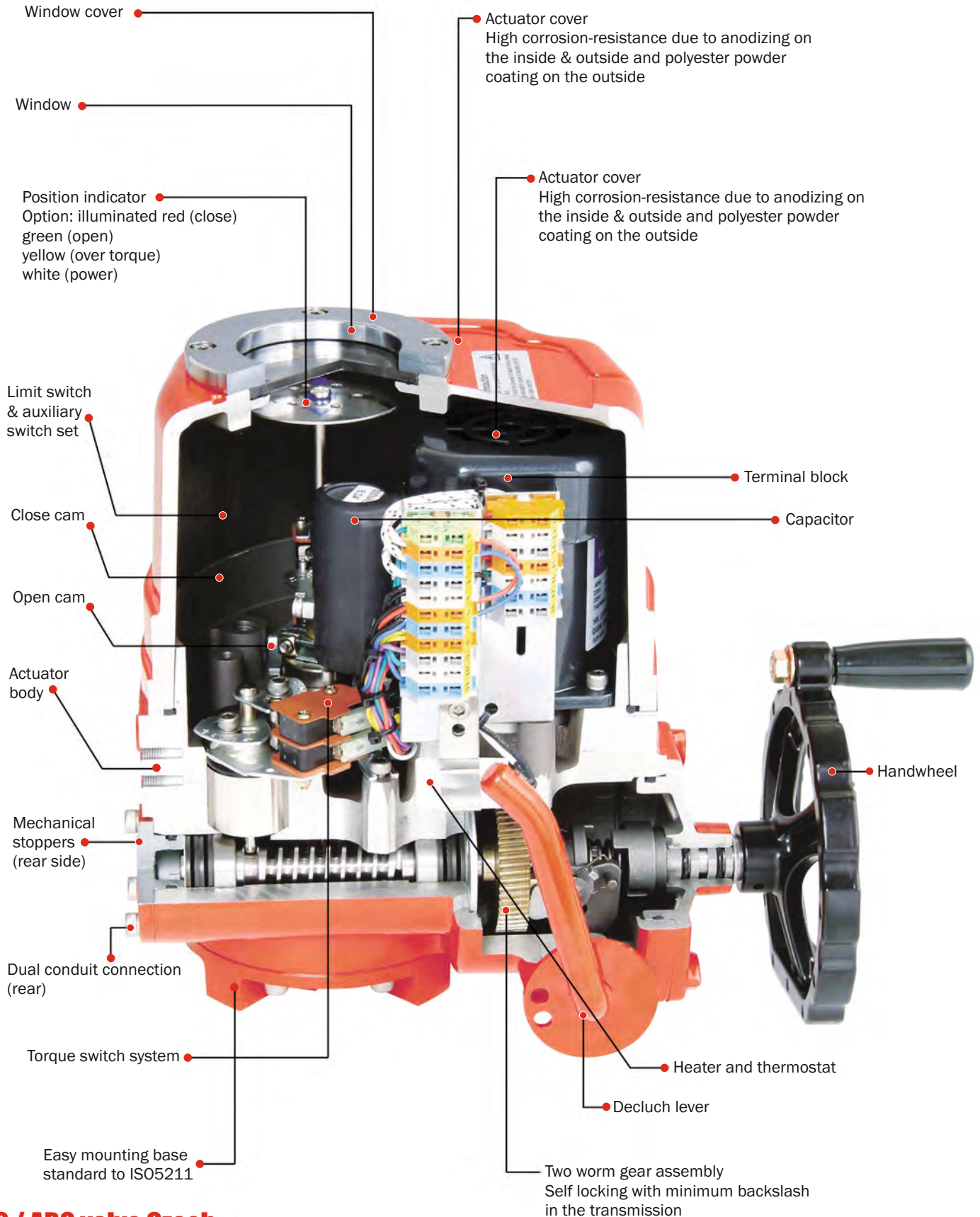

ELECTRIC ACTUATORS

S97AQ -015 / S97AQ-030 / S97AQ-060



Performance

S97AQ (model)	Maximum output torque Kg - m	Operating time (sec.) 60/50Hz	Maximum bore size mm	Motor class F power (W) 60Hz/50Hz		Rated current (A) 60Hz/50Hz				Duty cycle IEC 34-1 S4(%)	Number of handle turn N	Weight Kg
				1 Phase	3 Phase	1 Phase		3 Phase				
						110V	220V	380V	440V			
S97AQ - 015	15	21/25	∅22	185/166	112/216	1.70/1.50	0.84/0.73	0.28/0.37	0.36/0.59	70	11	16.6
S97AQ - 030	30	26/31	∅35	177/148	130/171	1.67/1.37	0.81/0.68	0.27/0.33	0.34/0.55	70	13.5	22
S97AQ - 060	60	26/31	∅35	390/410	184/236	3.56/4.27	1.30/1.40	0.42/0.51	0.47/0.66	70	13.5	23

Standard specification

Enclosure	Weatherproof enclosure IP67, NEMA 4 and 6
Power supply	110 / 220V AC 1PH, 380 / 440V AC 3PH 50 / 60Hz, ± 10%
Control power supply	110 / 220V AC 1PH, 50 / 60Hz, ± 10%
Duty cycle (on - off)	S2, 100% Max 30Min
Duty cycle (modulating)	S4, 70% Max 300 ~ 1600 start/hour
Motor	Induction motor (Reversible motor)
Limit switches	Open / close, SPDT, 250V AC 16A rating
Additional limit switches	Open / close, SPDT, 250V AC 16A rating
Torque switches	Open / close, SPDT, 250V AC 16A rating
Stall protection / operating temp	Built-in thermal protection, open 150 ± 5 / close 97 ± 15
Travel angle	90° ± 10° (0 ~ 110°)
Indicator	Continuous position indicator
Manual override	Declutching mechanism
Self locking	Provided by double worm gearing
Mechanical stopper	2x external adjustable screws
Space heater	10W (110 / 220V AC) Anti-condensation
Cable entries	Three PF 3/4" tap (standard type only)
Lubrication	Grease moly (EP type)
Terminal block	Spring loaded lever push type
Materials	Steel, Aluminium alloy, Al bronze, Polycarbonate
Ambient temperature	-20 °C ~ +70 °C (except option electronic board)
Ambient humidity	90% RH Max. (non-condensing)
Anti vibration	X Y Z 10g, 0.2 ~ 34Hz, 30 minute
External coating	Anodizing treatment before dry powder, Polyester



Dimensions

Model	BASE ISO 5211	A	D	E	F	G	H	I	J	K	L	M	N	O	P	Q	R	X	Y	Z
	∅ C	B																		
S97AQ - 015	F07/F10	M8/M10	22	125	3	42	73	200	65	142	87	200	68	54	78	160	17	338	229	268
	∅70 ∅102	12/15																		
S97AQ - 030	F10/F12	M10/M12	35	148	3	49	82	221	65	160	99	221	69	65	78	180	22	368	259	290
	∅102 ∅125	15/18																		
S97AQ - 060	F10/F12	M10/M12	35	148	3	49	82	221	65	160	99	235	69	65	78	180	27	368	259	304
	∅102 ∅125	15/18																		

Detail

