

ABO valve
Industrial Valve Manufacturer

DOUBLE OFFSET DOUBLE FLANGED BUTTERFLY VALVES

Body design	Double flanged
Nominal size	DN150 - DN2000
Working pressure	16 bar / 25 bar / 40 bar / 50 bar
Flange connection	PN6 / PN10 / PN16 / PN25 / PN40
Working temperature	-10 °C / +80 °C
Working media	Industrial water Potable water Sewage Low corrosive liquids
Tightness	Class A
Features	Double offset design Splitted stem Bidirectional sealing WRAS certification

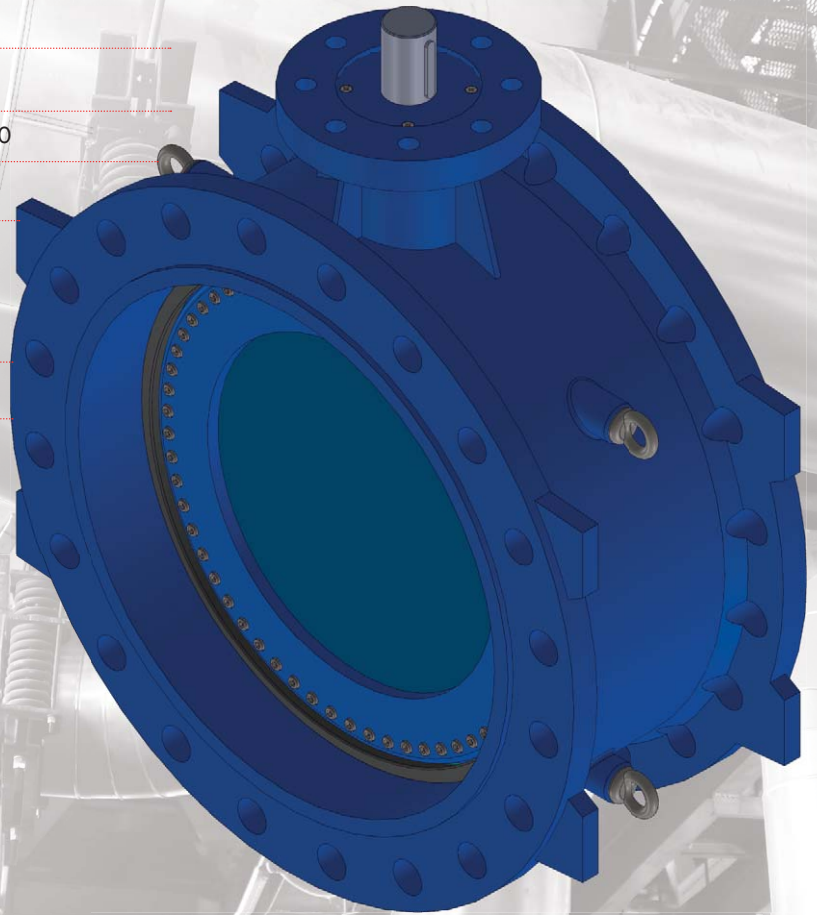

SERIES 2E3
power line

www.abovalve.com

GENERAL VALVE DESCRIPTION

Industrial Valve Manufacturer

Double offset double flanged butterfly valves Series 2E3 are suited for wide range of industrial applications including:

- sanitary installations
- industrial piping
- hydraulic equipment
- chilled water, potable water
- waste water
- irrigation & drainage systems
- sewage piping systems
- desalination

The butterfly valves Series 2E3 are not suitable for flow rate throttling. Disc's shafts should be always installed in horizontal positions.

General features

- double flanged valve design with double eccentricity
- on/off regulating device
- bi-directional sealing
- stainless steel sealing
- easy repair and maintenance
- easy installation and assembly
- WRAS certification

Quality control

- manufacturing at ABO valve is certified according to quality control standard ISO 9001:2015 (14001, 18001)
- tightness tests according to standards: ČSN EN 12266-1, ISO 5208, ANSI/FCI 70-2
- production in accordance with the Pressure Equipment Directive 2014/68/EU - Equipment operating under pressure (Category III, module H)
- all the ABO valves are tested under the pressure of 110% work pressure to ensure leak tightness according to standards - the 2.2/3.1/3.2 pressure test certificates can be issued
- valve actuators, if delivered, are adjusted and tested while assembled
- all certificates are downloadable from www.abovalve.com



Type designation

2E3 3 4 3 F 150

Nominal size (DN)

Body design
F - Double flanged

Disc material
3 - Ductile iron 0.7040 (GGG40)
6 - Ductile iron 0.7050 (GGG50)

Seat material
4 - Stainless steel 1.4301

Body material
3 - Ductile iron 0.7040 (GGG40)
6 - Ductile iron 0.7050 (GGG50)

Series name
Series 2E3

Standards

Design	EN 593
Leak test	EN 12266-1, Class A ISO 5208, Class A API 598
Face to face length	EN 558-1, Series 14 ISO 5752, Series 14 ISO 5752, Series 13
Flange connection	EN1092/BS4504 (DIN2501) ASME B16.5 Class 150
Top flange	EN ISO 5211

T-profiled disc seal ring fixed by retainer ensures reliable sealing performance in both directions, which is also easy to be adjusted or replaced without any special tools.

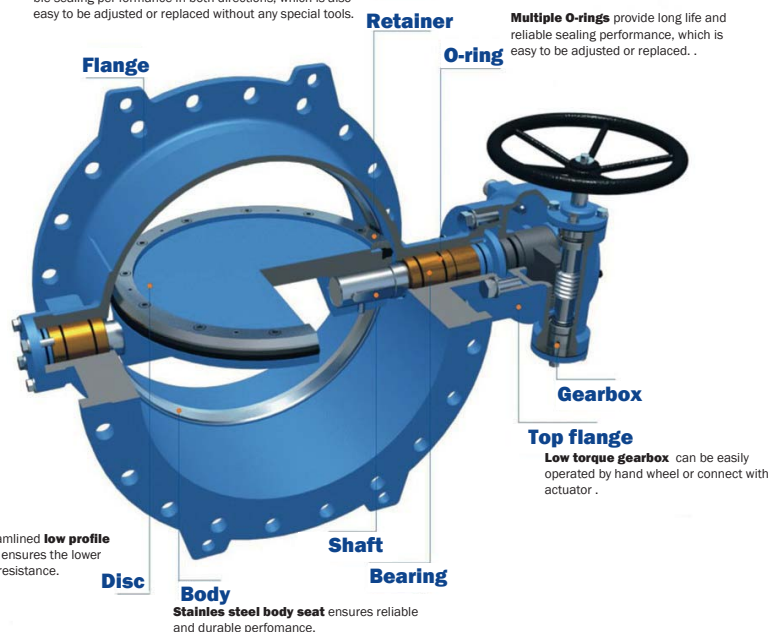

DESIGN ADVANTAGES



ABO valve

Design F
DOUBLE
FLANGED



Easy seat replacement

Possibility of replacement of the profile sealing ring without disassembling the disc.

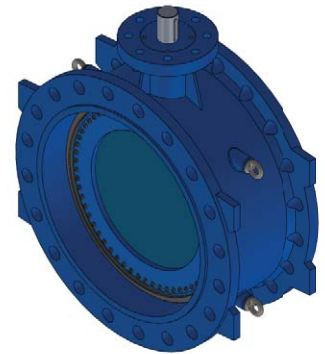
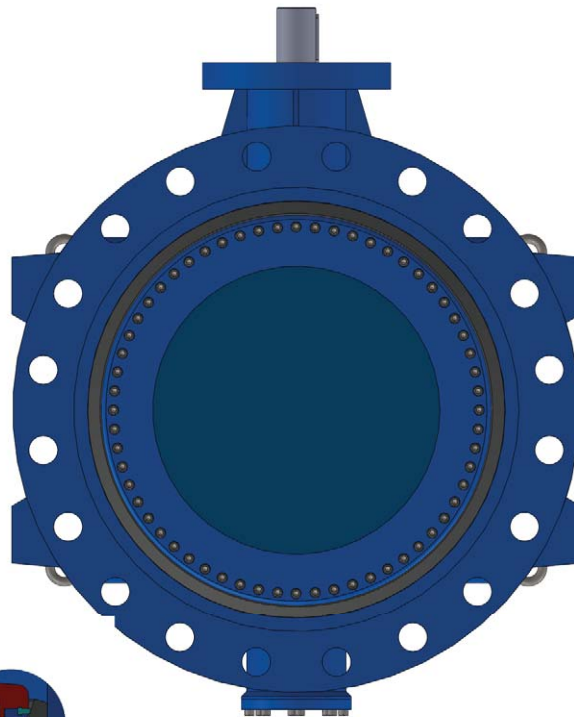

International standard compatibility

Top flange according ISO 5211 allows direct installation of manual gearboxes or actuators

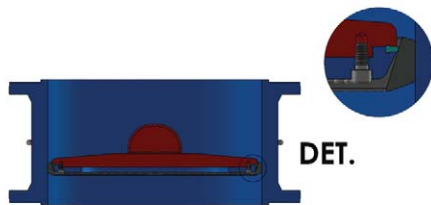

Improved sealing performance

Automatic sealing system with enclosed and pressure-supported profile sealing ring.

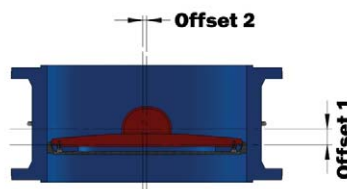

Double offset

Double offset design ensures perfect tightness and function of the valve, especially in case of water hammer. This offers results in fact during the first 10 degrees of opening and final 10 degrees of closing.

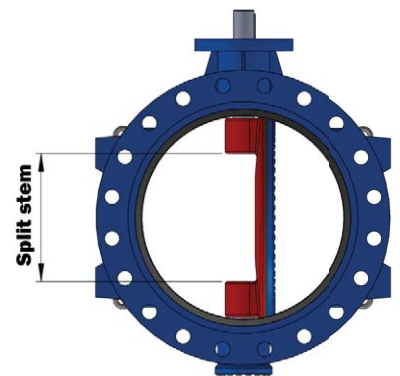

Split stem

Split stem allows higher flow rate and Kv value and lower pressure drop.

Installation between flanges (DN150-DN3000)

DN	150	200	250	300	350	400	450	500	600	700	800	900	1000	1100	1200	1400	1500	1600	1800	2000	2200	2400	2500	2600	3000		
PN10														X			X										
PN16																	X										
PN25														X										X	X	X	
PN40														X								X	X	X	X	X	

Standard

X Upon request

MATERIAL PERFORMANCE / TECHNICAL INFORMATION

Industrial Valve Manufacturer

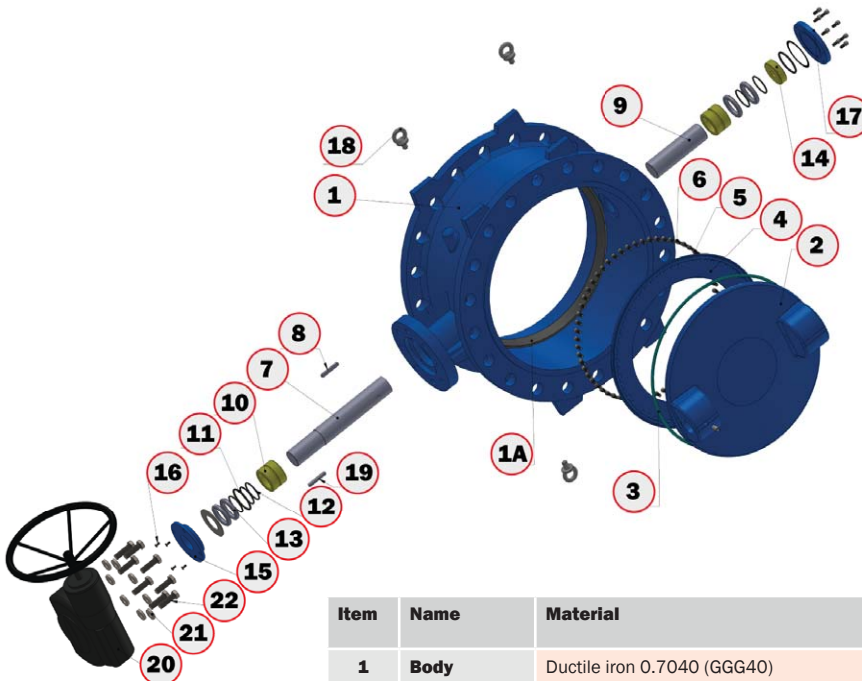

Coating

Epoxy coating is applied for excellent corrosion resistance. The coating is electrostatically applied (inside and outside), thickness 250 µm.

ABO valve coating is executed in blue finish RAL5005. Other color possibilities: RAL5015/RAL5017.

Item	Name	Material
1	Body	Ductile iron 0.7040 (GGG40) Ductile iron 0.7050 (GGG50) (GJS400-15 / GJS500-7)
1A	Body seat	Stainless steel 1.4301
2	Disc	Ductile iron 0.7040 (GGG40) Ductile iron 0.7050 (GGG50) (GJS400-15 / GJS500-7)
3	Disc sealing ring	Rubber (EPDM/NBR)
4	Retaining ring	Stainless steel 1.4301 (SS304) Stainless steel 1.4571
5	Bolt	Stainless steel A2
6	Screws	Stainless steel A4
7	Upper shaft	Stainless steel 1.4021 (SS420) Duplex stainless steel 1.4462 (S31803)
8	Key	Steel 1.4021 (SS420) Duplex stainless steel 1.4462 (S31803)
9	Lower shaft	Stainless steel 1.4021 Duplex stainless steel 1.4462 (S31803)

Item	Name	Material
10	Bushing	Bronze 2.0936
11,2	O-ring	Rubber (EPDM/NBR)
13,14	Adjustment ring	Delrin
15	End cover	Ductile iron GGG50 / GGG40
16	Bolt	Stainless steel A21
17	End cover	Ductile iron GGG50 / GGG40
18	Eye bolt	Steel A21CWCB
19	Key	Stainless steel 1.4021 (SS420) Duplex stainless steel 1.4462 (S31803)
20	Gearbox	Grey cast iron GG25 (0.6025)
21	Washer	Steel 1.0037
22	Bolt	Steel A2-70

Execution in other material types can be provided upon request. Choice of the seat and disc materials for various media will be recommended upon specific inquiry

DN	150	200	250	300	350	400	450	500	600	700	800	900
P _{MAX} 10 bar		315	505	788	1098	1591	2015	2623	4029	5758	8376	11387
P _{MAX} 16 bar	222	466	827	1163	1754	2341	3074	4135	6328	9166	13446	17794
P _{MAX} 25 bar	396	800	1346	2018	2731	3869	5085	6789	9958	15815	22048	27462
P _{MAX} 40 bar	721	1206	2042	3230	4535	6049	9532	8567	13249	27154	27596	37516

DN	1000	1100	1200	1300	1400	1500	1600	1700	1800	2000	2200	2400
P _{MAX} 10 bar	15268	20252	23567		33714	40972	48968		67936	90666	115614	150482
P _{MAX} 16 bar	23843	30342	37685		53058	56484	81921		107690	139344		
P _{MAX} 25 bar	39462		49698		88368	92579	127759					
P _{MAX} 40 bar	47534	71004	108230		126595	153086						

Bare shaft torques.

MAIN DIMENSIONS / PN10

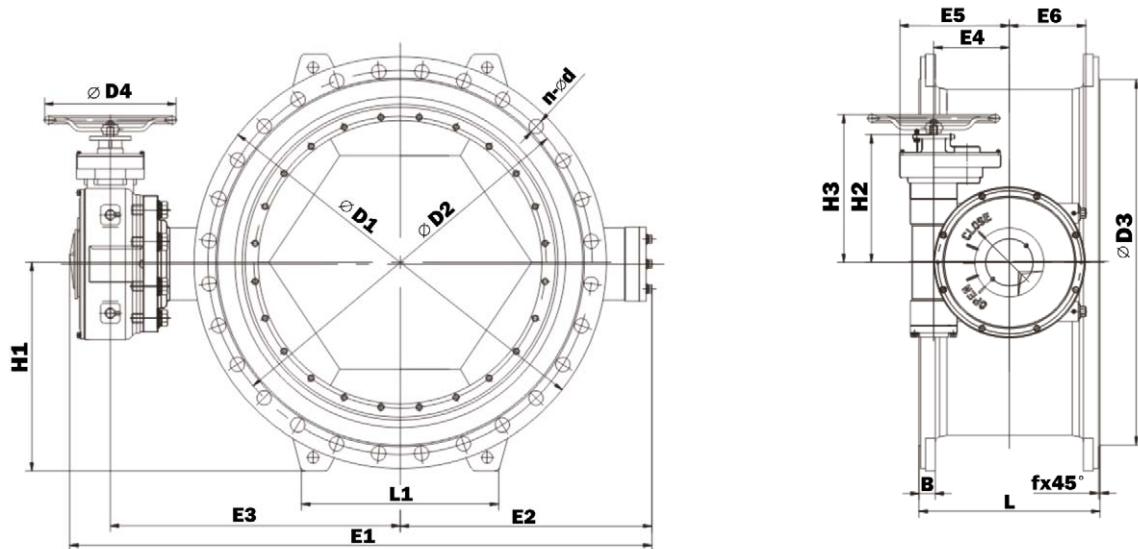

PN10

DN	D1	D2	D3	B	f	L		n-d	H1	H2	H3	E1	E2	E3	E4	E5	E6	L1	D4
						series 14	series 13												
200	Ø340	Ø295	Ø266	20	3	230	152	8-Ø23	175	137	193	526	198	272	64	99	86	196	240
250	Ø395	Ø350	Ø319	22	3	250	165	12-Ø23	202,5	137	193	568	219	293	64	99	86	240	240
300	Ø445	Ø400	Ø370	24,5	4	270	178	12-Ø23	227,5	178	233	670	254	351	93,4	135	115	260	320
350	Ø505	Ø460	Ø429	24,5	4	290	190	16-Ø23	257,5	178	233	720	279	376	93,4	135	115	280	320
400	Ø565	Ø515	Ø480	24,5	4	310	216	16-Ø28	287,5	192	283	834	320	432	120	169	138	310	400
450	Ø615	Ø565	Ø530	25,5	4	330	222	20-Ø28	312,5	192	283	903	359	462	120	169	138	340	400
500	Ø670	Ø620	Ø582	26,5	4	350	229	20-Ø28	340	317	378	988	393	513	120	186	138	370	400
600	Ø780	Ø725	Ø682	30	5	390	267	20-Ø31	395	315	376	1119	450	580	148	214	166	430	400
700	Ø895	Ø840	Ø794	32,5	5	430	292	24-Ø31	452,5	315	376	1217	530	598	148	214	166	480	400
800	Ø1015	Ø950	Ø901	35	5	470	318	24-Ø34	512,5	346	407	1410	614	691	185	265	196	560	400
900	Ø1115	Ø1050	Ø1001	37,5	5	510	330	28-Ø34	562,5	346	407	1530	675	750	185	265	196	615	400
1000	Ø1230	Ø1160	Ø1112	40	5	550	410	28-Ø37	620	390	451	1712	748	839	230	333	232	670	400
1200	Ø1455	Ø1380	Ø1328	45	5	630	470	32-Ø41	732,5	451	512	1971	865	981	230	368	232	800	400
1400	Ø1675	Ø1590	Ø1530	46	5	710	530	36-Ø44	842,5	507	568	2313	1011	1138	315	453	327	920	400
1500	Ø1785	Ø1700	Ø1640	48	5	750	565	36-Ø44	897,5	507	568	2489	1112	1213	315	453	327	980	400
1600	Ø1915	Ø1820	Ø1750	49	5	790	600	40-Ø50	962,5	507	568	2588	1161	1263	315	453	327	1050	400
1800	Ø2115	Ø2020	Ø1950	52	5	870	670	44-Ø50	1063	599	660	3038	1324	1501	412	613	408	1162	400
2000	Ø2325	Ø2230	Ø2150	55	5	950	760	48-Ø50	1168	599	660	3255	1436	1606	412	613	408	1270	400

If there is any request for larger sizes, please consult with us

Face to face length acc. to EN588-1 Series 14/13 (ISO 5752 Series 14/13, DIN 3202 F4/F16).
Flange dimensions and drilling acc. to EN1092-2 (ISO 7005-2).

MAIN DIMENSIONS / PN16

Industrial Valve Manufacturer

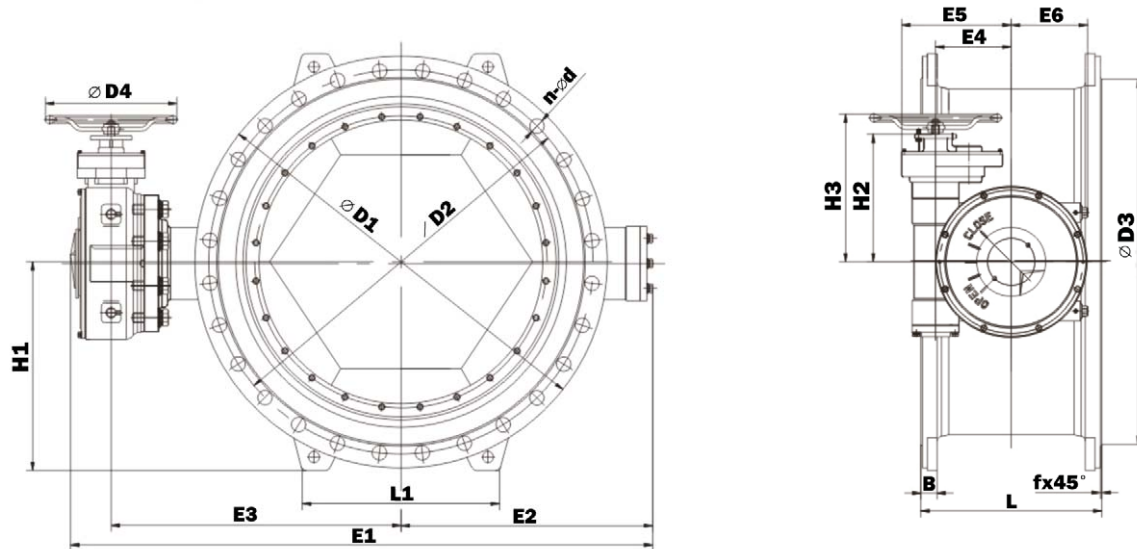

PN16

DN	D1	D2	D3	B	f	L		n-d	H1	H2	H3	E1	E2	E3	E4	E5	E6	L1	D4
						series 14	series 13												
200	Ø340	Ø295	Ø266	20	3	230	152	12-Ø3	175	137	193	526	198	272	64	99	86	196	240
250	Ø405	Ø355	Ø319	22	3	250	165	12-Ø28	207,5	178	233	622	230	328	93,4	135	115	240	320
300	Ø460	Ø410	Ø370	24,5	4	270	178	12-Ø28	235	178	233	670	254	351	93,4	135	115	275	320
350	Ø520	Ø470	Ø429	26,5	4	290	190	16-Ø28	265	192	283	784	295	407	120	169	138	290	400
400	Ø580	Ø525	Ø480	28	4	310	216	16-Ø31	295	192	283	853	334	437	120	169	138	310	400
450	Ø640	Ø585	Ø548	30	4	330	222	20-Ø31	325	317	378	938	368	488	120	186	138	360	400
500	Ø715	Ø650	Ø609	31,5	4	350	229	20-Ø34	362,5	315	376	1019	400	530	148	214	166	470	400
600	Ø840	Ø770	Ø720	36	5	390	267	20-Ø31	425	315	376	1117	480	548	148	214	166	395	400
700	Ø910	Ø840	Ø794	39,5	5	430	292	20-Ø37	460	346	407	1308	563	640	185	265	196	480	400
800	Ø1025	Ø950	Ø901	43	5	470	318	24-Ø41	517,5	346	407	1426	623	698	185	265	196	560	400
900	Ø1125	Ø1050	Ø1001	46,5	5	510	330	28-Ø41	567,5	390	451	1612	698	789	230	265	232	618	400
1000	Ø1255	Ø1170	Ø1112	50	5	550	410	28-Ø44	635,5	451	512	1773	766	882	230	333	232	600	400
1200	Ø1485	Ø1390	Ø1328	57	5	630	470	32-Ø50	737,5	507	568	2112	910,5	1038	315	368	327	800	400
1400	Ø1685	Ø1590	Ø1530	60	5	710	530	36-Ø50	847,5	599	660	2529	1063	1253	412	453	408	920	400
1500	Ø1820	Ø1710	Ø1640	62,5	5	750	565	36-Ø57	915	599	660	2633	1120	1300	412	453	408	1000	400
1600	Ø1930	Ø1820	Ø1750	65	5	790	600	36-Ø57/4-M52	970	599	660	2754	1172	1369	412	453	408	1060	400
1800	Ø2130	Ø2020	Ø1950	70	5	870	670	36-Ø57/8-M52	1070	777	838	3257	1416	1602	495	613	485	1170	600
2000	Ø2345	Ø2230	Ø2150	75	5	950	760	48-Ø62	1178	777	838	3523	1583	1701	495	613	485	1290	600

If there is any request for larger sizes, please consult with us

Face to face length acc. to EN588-1 Series 14/13 (ISO 5752 Series 14/13, DIN 3202 F4/F16).
Flange dimensions and drilling acc. to EN1092-2 (ISO 7005-2).

6 / ABO Valve Czech

MAIN DIMENSIONS / PN25

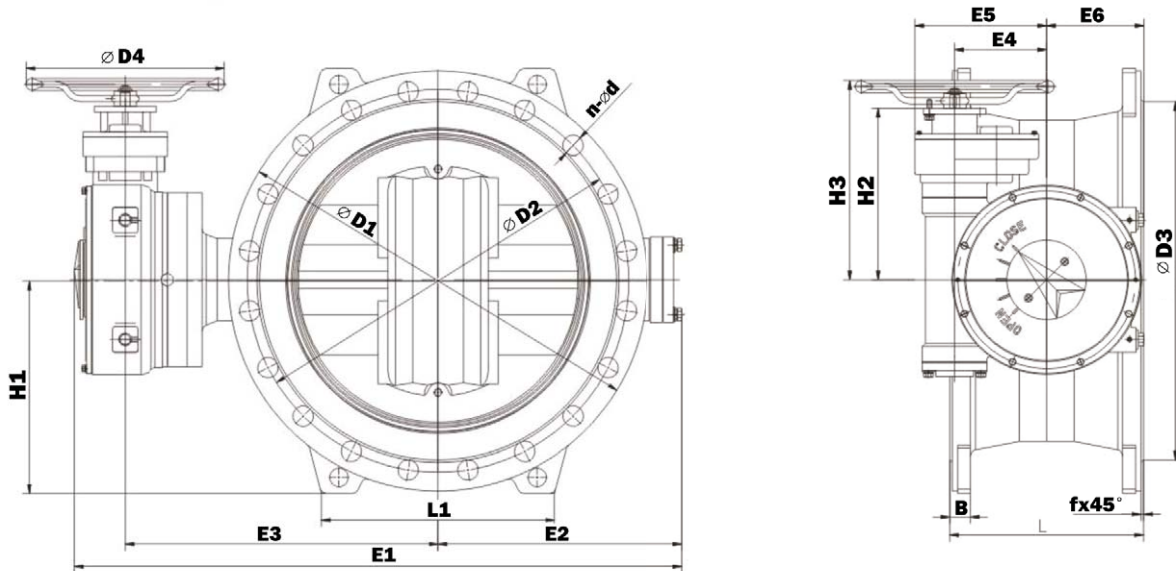

PN25

DN	D1	D2	D3	B	f	L series 14	n-d	H1	H2	H3	E1	E2	E3	E4	E5	E6	L1	D4
200	Ø360	Ø310	Ø274	22	3	230	12-Ø28	190	178	233	586	221	300	93,4	135	115	220	320
250	Ø426	Ø370	Ø330	25	3	250	12-Ø31	220	178	233	656	254	337	93,4	135	115	260	320
300	Ø485	Ø430	Ø389	28	4	270	16-Ø31	250	192	283	757	298	377	120	169	138	300	400
350	Ø555	Ø490	Ø448	30	4	290	16-Ø34	285	317	378	830	318	430	120	186	138	320	400
400	Ø620	Ø530	Ø503	32	4	310	16-Ø37	315	315	376	945	370	486	148	214	166	350	400
450	Ø670	Ø600	Ø548	34,5	4	330	20-Ø37	340	315	376	991	406	496	148	214	166	371	400
500	Ø730	Ø660	Ø609	37	4	350	20-Ø37	370	346	407	1112	453	554	185	265	196	410	400
600	Ø845	Ø770	Ø720	42	5	390	20-Ø41	427,5	346	407	1235	495	631	185	265	196	470	400
700	Ø960	Ø875	Ø820	46,5	5	430	24-Ø44	485	390	451	1398	569	704	230	333	232	530	400
800	Ø1085	Ø990	Ø928	51	5	470	24-Ø50	547,5	390	451	1571	646	800	230	333	232	600	400
900	Ø1185	Ø1090	Ø1028	45,5	5	510	28-Ø50	597,5	451	512	1669	695	849	230	368	232	655	400
1000	Ø1320	Ø1210	Ø1140	60	5	550	24-Ø57/4 -M52	665	507	568	1923	779	980	315	353	327	730	400
1200	Ø1530	Ø1420	Ø1350	69	5	630	32-Ø57	770	599	660	2252	903	1136	412	613	408	840	400
1400	Ø1755	Ø1640	Ø1560	74	5	710	36-Ø62	882,5	599	660	2516	1041	1262	412	613	408	970	400
1500	Ø1865	Ø1750	Ø1678	77,5	5	750	36-Ø62	937,5	599	660	2651	1130	1308	412	613	408	1030	400
1600	Ø1975	Ø1860	Ø1780	81	5	790	36-Ø62/4 -M56	992,5	777	838	2852	1208	1405	495	725	485	1080	600

If there is any request for larger sizes, please consult with us

Face to face length acc. to EN588-1 Series 14/13 (ISO 5752 Series 14/13, DIN 3202 F4/F16).
Flange dimensions and drilling acc. to EN1092-2 (ISO 7005-2).

MAIN DIMENSIONS / PN40

Industrial Valve Manufacturer

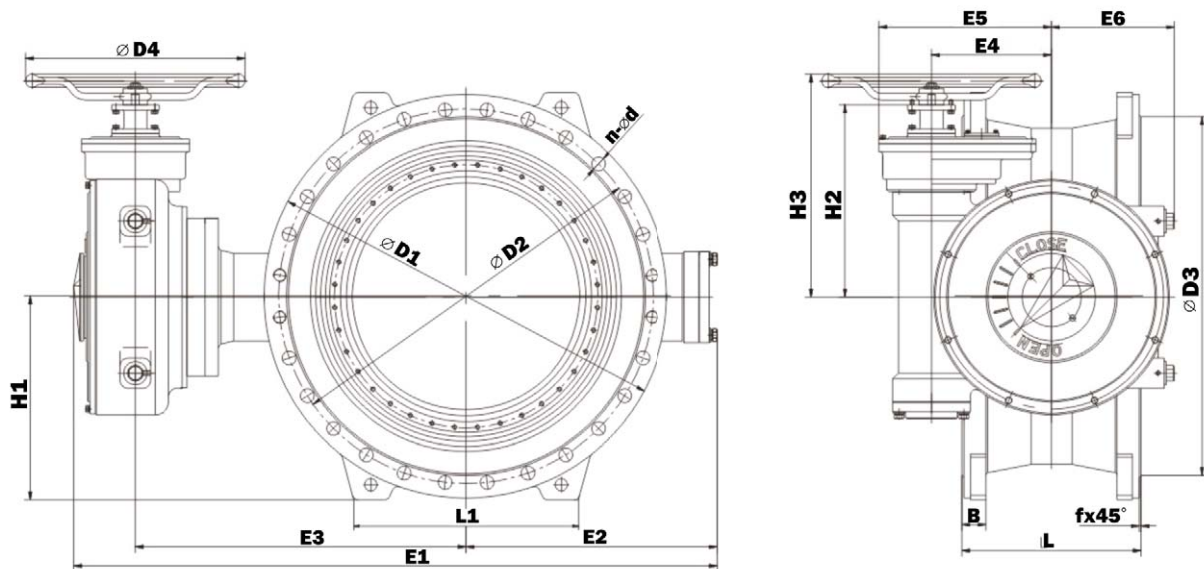

PN40

DN	D1	D2	D3	B	f	L		n-d	H1	H2	H3	E1	E2	E3	E4	E5	E6	L1	D4
						series	14												
200	Ø375	Ø320	Ø284	30	3	230		12- Ø31	192,5	178	233	603	229	309	93,4	135	115	180	320
250	Ø450	Ø385	Ø345	35	3	250		8- Ø34/4 -M30	230	192	283	712	261	369	120	169	138	200	400
300	Ø515	Ø450	Ø409	40	4	270		12- Ø34/4 -M30	262,5	317	378	795	305	408	120	186	138	240	400
350	Ø580	Ø510	Ø465	44	4	290		12- Ø37/4 -M33	295	315	376	904	360	455	148	214	166	320	400
400	Ø660	Ø585	Ø535	48	4	310		12- Ø41/4 -M36	335	315	376	1001	407	505	148	214	166	320	400
450	Ø685	Ø610	Ø560	49	4	330		16- Ø41/4 -M36	347,5	346	407	1067	429	533	185	265	196	360	400
500	Ø755	Ø670	Ø615	52	4	350		16- Ø44/4 -M39	382,5	346	407	1180	477	598	185	265	196	450	400
600	Ø890	Ø795	Ø735	58	5	390		16- Ø50/4 -M45	450	390	451	1363	555	683	230	333	232	500	400
700	Ø995	Ø900	Ø840	64	5	430		20- Ø48/4 -M45	505	507	568	1625	666	795	315	453	327	560	400
800	Ø1140	Ø1030	Ø960	72	5	470		20- Ø56/4 -M52	575	507	568	1696	664	868	315	453	327	630	400
900	Ø1250	Ø1140	Ø1070	76	5	510		24- Ø56/4 -M52	635	507	568	1904	785	955	315	453	327	690	400
1000	Ø1360	Ø1250	Ø1180	80	5	550		24- Ø56/4 -M52	690	599	660	2039	837	989	412	613	408	740	400
1200	Ø1575	Ø1460	Ø1380	88	5	630		24- Ø62/8 -M56	792,5	777	838	2595	1077	1279	495	725	485	860	600
1400	Ø1795	Ø1680	Ø1600	98	5	710		28- Ø62/8 -M56	902,5	777	838	2839	1200	1400	495	725	485	1000	600
1500	Ø1925	Ø1800	Ø1715	105	5	750		28- Ø70/8 -M64	967,5	777	838	3041	1305	1497	495	725	485	1060	600
1600	Ø2025	Ø1900	Ø1815	108	5	790		32- Ø70/8 -M64	1018	958		3252	1410	1520	560	820	566	1100	

If there is any request for larger sizes, please consult with us

Face to face length acc. to EN588-1 Series 14/13 (ISO 5752 Series 14/13, DIN 3202 F4/F16).
Flange dimensions and drilling acc. to EN1092-2 (ISO 7005-2).

8 / ABO Valve Czech

RUBBER LINED OPTION / MAIN FEATURES



CONTACT US

Industrial Valve Manufacturer



Czech Republic

ABO valve, s.r.o.
Dalimilova 285/54
783 35 Olomouc
tel.: +420 585 224 087
sales@abovalve.com

Slovak Republic

ABO Slovakia, s.r.o.
Banská Bystrica
tel.: +421 947 902 862
sales.sk@abovalve.com

Germany

ABO Armaturen GmbH
Essen
tel.: +49 (0)152 262 29501
sales.de@abovalve.com

USA

ABO Controls LLC
Houston
tel.: +(1) 832.291.4929
sales.us@abovalve.com

Ukraine

ABO Ukraine LLC
Dnipro
tel.: +38 056 733 95 70
sales.ua@abovalve.com

Turkey

ABO Armaturen LTD STI
Istanbul
tel.: +90 216 527 36 34
sales.tr@abovalve.com

Russia

ABO Armatura LLC
Smolensk
tel.: +7 (4812) 240 020
sales.ru@abovalve.com

India

ABO Controls Pvt. Ltd.
Mumbai
tel.: +91 773 820 4779
sales.in@abovalve.com

Singapore

ABO Valve Pte. Ltd.
Singapore
tel.: +65 9169 4562
sales.sg@abovalve.com

China

ABO Flow Control
Shanghai
tel.: +86 136 01 522 831
sales.cn@abovalve.com

United Arab Emirates

Sales representation
Abu Dhabi
tel.: +971 56 9207964
bharti@abovalve.com

Bahrain

Sales representation
Manama
tel.: +973 3444 9065
jimnichen@abovalve.com



Follow us on:



www.abovalve.com



The technical information described in this leaflet is tentative and for general use only and does not constitute a recommendation or guarantee for any specific service or application requirement. Please consult ABO representative or factory for specific requirements and material selection for your intended application. The right to change or modify product design or product without prior notice is reserved. ABO valve accepts no liability for damages caused by bad interpretation or use of the information included in this brochure.