

# *Operating Instructions*

## *For ABO Butterfly Valves, Series 3 E DN150-400*



- 1. Introduction**
- 2. Safety Instructions**
- 3. Valve Model**
- 4. Transportation and Storage**
- 5. Installation into Piping**
- 6. Pipe Pressure Test**
- 7. Operation and Maintenance**
- 8. Assistance in Case of Failure**
- 9. Valves with Electric or Pneumatic Actuator**
- 10. Other Information**

## 1. Introduction

Triple-offset butterfly valves, Series 3E DN150-400 have been designed for very demanding industrial applications requiring high security and reliability.

They are mainly used in heat generation industry and applications with high temperature mediums (up to 500° C and pressure up to 40 bar – see pressure/temperature diagram).

**WCB body - pressure/temperature working diagram**

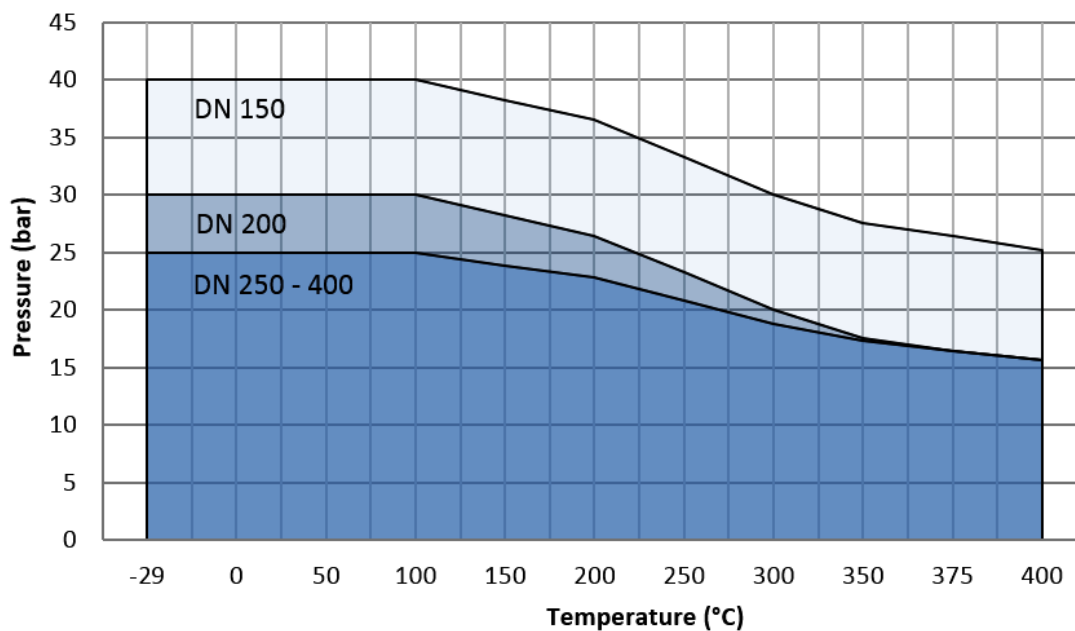

**A351 CF8M body - pressure/temperature working diagram**

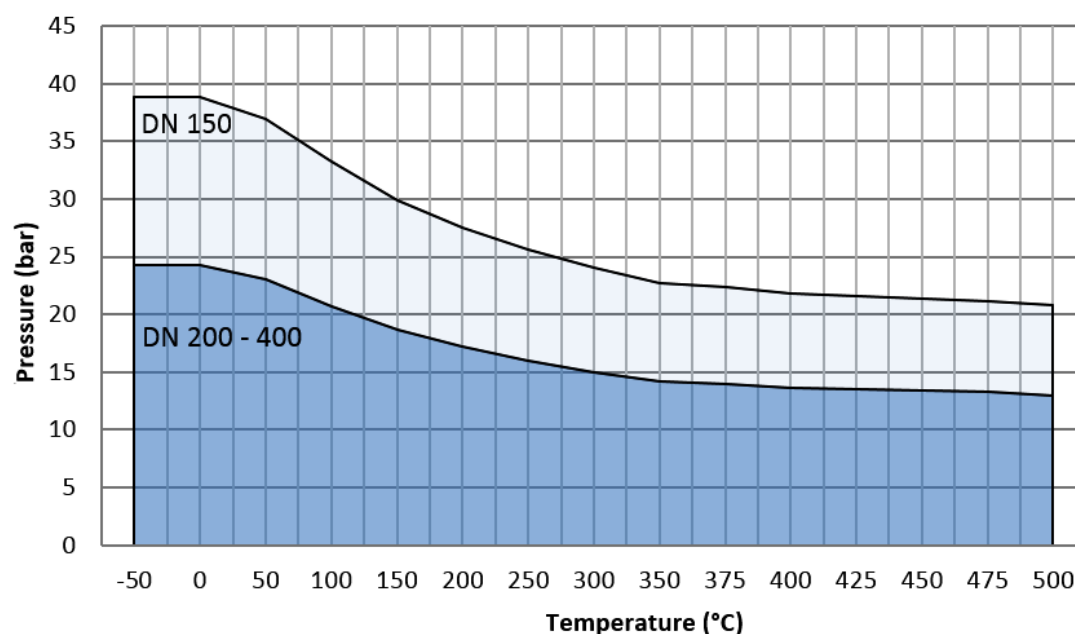

The correct type and material design is determined using brochures and technical data sheets, or consultations with the manufacturer.

Check valves of Series 3 E are in full compliance with the directive CE/97/23.

## 2. Safety Instructions

Installation, operation and maintenance may only be performed by properly trained and instructed staff.

For detailed safety regulations see the separate document, which must be read carefully before installation.

## 3. Valve Model

Valves come with a body with through holes (marked "B"), threaded holes (marked "T") of a flange or welded design.

Inner diameter range:	DN 150 to DN 400
Operating pressure:	up to 40 bar
Material design:	carbon steel stainless steel

Each butterfly valve is provided with an identification label in accordance with ČSN EN 19.

Maximum and minimum operating temperatures TS max, TS min depending on the operating pressure PS for various material designs are listed in the charts included in the appropriate brochures.

## 4. Transportation and Storage

Valves must be stored indoors in dry and dust-free environment at normal temperatures.

Valves with manual gears, electric and double acting actuators are stored in a slightly open position (never fully closed!).

Valves with spring pneumatic actuators are stored in fail safe position (open position with additional disc protection).

Valves must always be handled in keeping with all the safety standards:

- Lifting and handling must be carried out by qualified staff,
- Use lifting equipment with sufficient load-bearing capacity, including loops and ropes,
- Three-point method of rope attachment (balancing) is recommended,

- No part of the lifting system (loops...) may come into contact with the components of valve actuators.

## 5. Installation into Piping

Butterfly valves may be installed in the piping system between two flanges.

Installation at the end of the pipe is allowed only with counter flange, or in the opposite direction without a counter flange ("T" version only!) but with reduced allowed working pressure ( $P_{\text{working}} \times 0,7$ ).

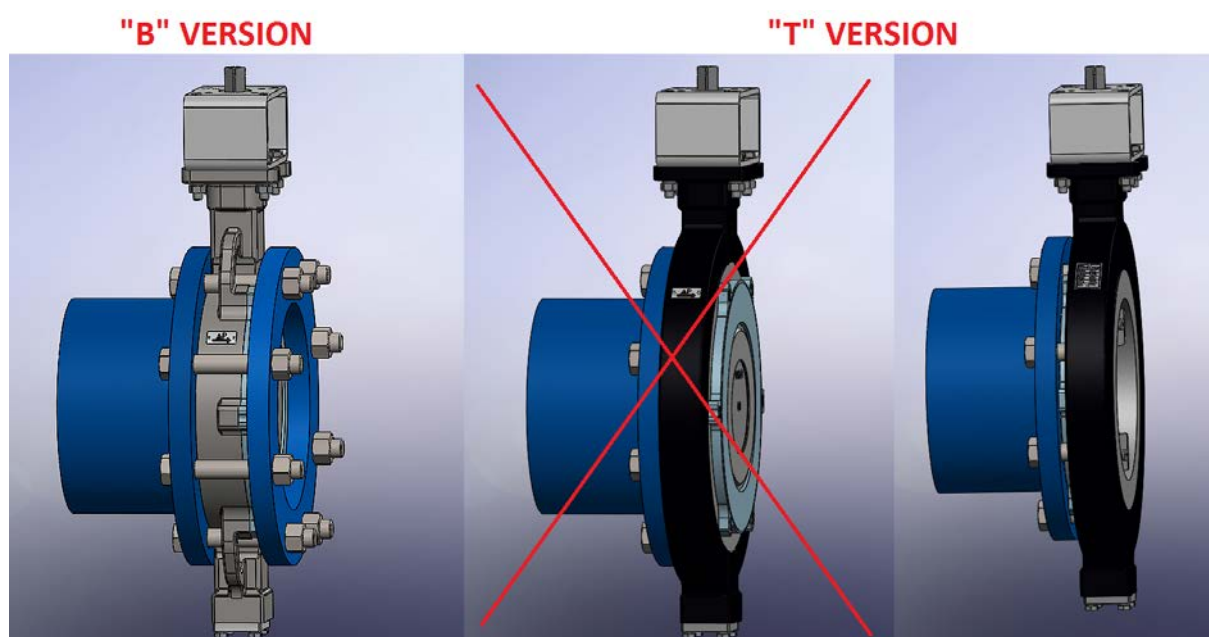

Prior to the installation it is necessary to check whether the PN, DN and material design of the supplied valve corresponds to the intended use.

The procedure is graphically described in the document **Installation Instructions**.

Flanges with flat sealing surfaces e.g. B shape according to EN 1092 and also appropriate gasket must be used.

Before installation it is necessary to examine:

- Whether the PN, DN and materials of the supplied valve correspond to the intended use.
- Whether no damage, namely to the sealing surfaces of the disc, occurred during transportation. **Do not use damaged valves!**
- Check the correct function of the valve (full opening and closing).
- The flanges must have a gasket strip, and they must be aligned and parallel, any impurities and solid particles must be removed from the flanges and piping.

When manufactured, valves with a carbon steel body are preserved using the oil preservative RUST-PEL 51. (If stored for more than 6 months, a new preservation treatment is recommended).

Prior to putting into operation, the preservation of the valve body needs to be removed by using a warm aqueous solution containing a common detergent or solvent such as E 550 CLEAN or similar.

A gasket made of a material resistant to the used medium is placed between the valve and the flange.

The arrow on the body shows the direction of the flow (direction  $\Delta p$ ).

After centring the valve in the pipe, slightly tighten the 4 bolts and check if the disc moves freely. Tighten all the bolts ("in a cross-cross pattern").

The heads of the opposite bolts in "T" type bodies must not be in touched!

After re-tightening the bolts check if the disc moves freely.

## 6. Pipe Pressure Test

The actual valve is pressurized by the manufacturer. When fitted in the pipeline the entire pipe section with valves needs to be pressurized. The following must be taken in consideration:

- A newly installed section must be carefully rinsed (cleaned) to remove all the mechanical impurities,
- Valves in open position: pressure at 1.5 times the PN,
- Valves in closed position: pressure at 1.1 times the PN.

## 7. Operation and Maintenance

Valves can be manually controlled using the appropriate force.

The valves are maintenance-free, it is only necessary to check if the outer surface and the stem seal do not leak while in operation.

If the valve remains in the same position for a long time, it is recommended to close and open the valve repeatedly at least 4 times per year.

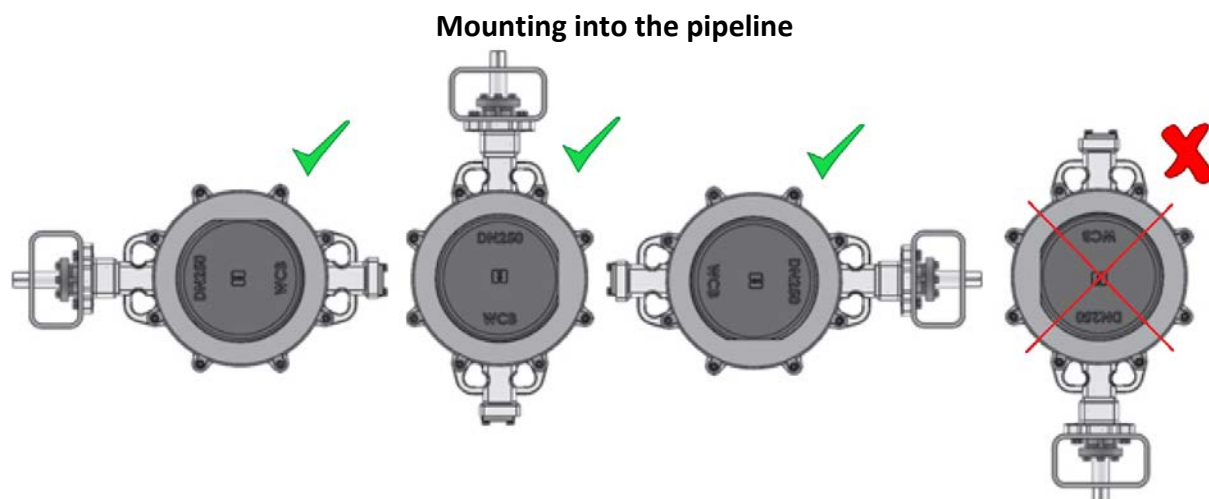

## 8. Assistance in Case of Failure

In case of failure and repair it is necessary to follow to all safety rules - see the separate document **Safety Instructions**.

Failure	Measure	Note
Leakage between the valve and flanges	Tighten the flange bolts. In case of ongoing leakage, replace the sealing between the valve and flanges.	
Leakage between the valve body and the flange	Repair by the manufacturer required.	
Closure leakage	Check if the valve is fully closed. Open and close the valve repeatedly. If the leakage persists, repair by the manufacturer is required.	
Leakage around the stem	All the nuts and gland retainer must be tightened (alternatively at a quarter of a turn). If the leakage persists, repair by the manufacturer is required.	If the nut of the gland retainer must be removed, make sure the piping is not under pressure!
Function defect	Remove and check the fitting. If damaged, send to the manufacturer.	See the Safety Instructions!

## 9. Valves with electric or pneumatic actuator

The above principles fully apply to these valves.

The positions of the actuators have been pre-set by the manufacturer and may not be adjusted.

The inlet (or outlet) of controlling air in pneumatic actuators can be adjusted to avoid their quick closure and the water hammer in the pipes.

Actuator mounted by the customer:

- ☞ Closing torque of the actuator must not be higher than maximum allowable stem torque see attached table (MAST)!
- ☞ Check actuator and valve connection!
- ☞ Do not use excessive force in assembly!
- ☞ The action of the axial force to the shaft is not allowed!

Valve	Min. closing moment (water/air) (Nm)	Maximum allowable stem torque (Nm)	Opening moment (Nm) at delta P (bar)					
			10 bar	16 bar	20 bar	25 bar	30 bar	40 bar
DN150 - 35Lx	220	635	110	140	190	210	261	350
DN150 - 34Lx	220	476	110	140	190	210	261	350
DN200 - 35Lx	450	635	280	330	370	490	550	
DN200 - 34Lx	450	476	280	330	370	490	550	
DN250 - 35Lx	420 / 565	1097	283	418	460	656		
DN250 - 34Lx	420 / 565	822	283	418	460	656		
DN300 - 35Lx	400 / 550	1742	600	900	1030	1150		
DN300 - 34Lx	400 / 550	1300	600	900	1030	1150		
DN400 - 35Lx	500/1300	5078	1600	2270	2430	3100		
DN400 - 34Lx	500/1300	3800	1600	2270	2430	3100		

#### Electric actuators settings:

- Set closing torque switch (min. closing torque x 1,25. Except DN200 34Lx where max. moment is 476Nm!)
- Mechanical endstop for position „close“ and position switch can not be used!
- Set opening torque switch (opening moment x 1,25. Except DN200 34Lx where max. moment is 476Nm!)
- Set mechanical endstop for position „open“ and then set position switch

#### Double action pneumatic actuators settings:

- Compare opening and closing moment, choosing the higher and submit safety coefficient x 1,25 (or MAST torque when it is the lowest one)
- For accuracy perform the calculation of required pressure and use the pressure reducer
- Set only mechanical endstop for position „open“ (stop end for close position must be free!)

#### Spring to close pneumatic actuators settings:

- Choose quantity of spring for min. closing torque x 1,25 (except DN200 34Lx where max. torque is 476Nm!)
- Choose required air pressure for opening moment x 1,25 (except DN200 34Lx where max. torque is 476Nm!) and then set the pressure reducer.
- Set only mechanical endstop for position „open“ (endstop for position „close“ must be free!)

#### Spring to open pneumatic actuators settings:

- Choose quantity of spring for opening torque x 1,25 (except DN200 34Lx where max. moment is 476Nm!)
- Choose required air pressure for closing torque x 1,25 (*except DN200 34Lx where max. moment is 476Nm!*) and then set the pressure reducer.
- Set only mechanical endstop for position „open“ (endstop for position „close“ must be free!)

**Manual gear settings:**

- Compare opening and closing torque, choosing the higher and submit safety coefficient x 1,25 (or MAST value when is the lowest one)
- Calculate diameter of handwheel for standard human strength by the standards of the country
- Set only mechanical endstop for position „open“ (endstop for position „close“ must be free!)

**10.INSTALLATION manual for the 3E valve (installation in piping or testing bench)**

- 1) Place the valve into the testing bench (or in piping) in slightly open position
- 2) Gently fasten the valve between flanges
- 3) With respect to the specified operating torque fully close the valve
- 4) Completely finish the fastening of the valve between flanges

Not observing of the above mentioned notes can cause damage or leakage of the valve

To justify the eventual claim, it is necessary to respect above mentioned steps once installing the valve in piping.

This installation process is mandatory for every installation of this type of the valve in piping or testing bench – even the repeated one.

**11.Other Information**

Correct shaft position on closed valve:

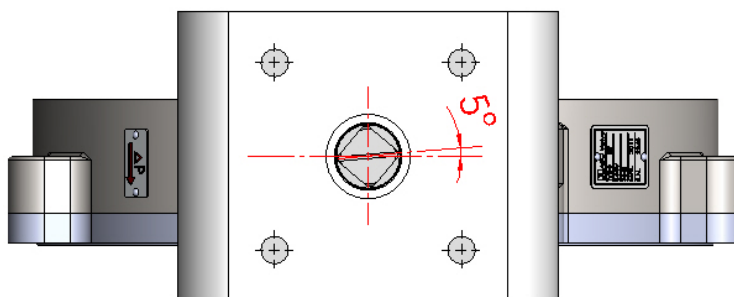

Pressure tightness testing:



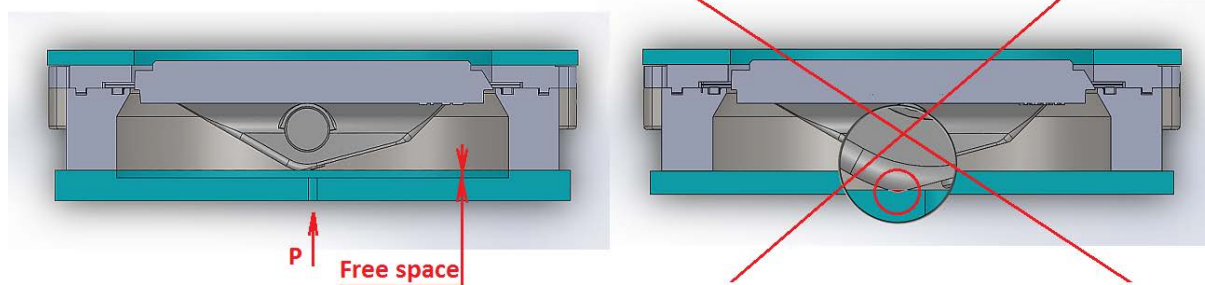

These regulations as well as other above-mentioned documents and further information – also in other languages – are available at [www.abovalve.com](http://www.abovalve.com) or at the following address:

ABO valve, s.r.o.  
Dalimilova 285/54  
783 35 Olomouc  
Czech Republic

Tel: 00420 585 223 955  
Fax: 00420 585 223 984  
[abovalve@abovalve.com](mailto:abovalve@abovalve.com)  
[www.abovalve.com](http://www.abovalve.com)

Last revision: 17<sup>th</sup> February 2017